

### Type HB - Hollo-Bolt®

- Steel, bright zinc plated plus JS500
- Steel, sheraplex
- Steel, hot dip galvanised (Hex Head only)
- Stainless Steel Grade 316

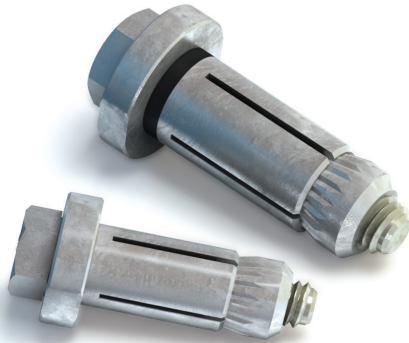

Suitable for hollow sections, tubes and where access is available from one side only. The Hollo-Bolt is continuously developed to meet the requirements of Structural Engineers, with recent performance improvements including the patented High Clamping Force (HCF) version (see page 40). The Hollo-Bolt is protected by multiple international patents and registered designs.



### Lindapter Hollo-Bolt Head Variations



#### Hexagonal

*Visible protrusion:* Normal  
The Hollo-Bolt collar and hexagonal head of the Grade 8.8 bolt are evident above the surface of the steel section. This head variant is the usual choice for the majority of SHS connections, or where architects favour an 'industrial' look.



#### Countersunk (Bolt Head)

*Visible protrusion:* Minimal  
This discreet midway option has a smaller protrusion for the perfect balance of appearance and convenience, and features a Grade 10.9 countersunk bolt with a special collar designed to accommodate the entire bolt head. Drilling countersunk holes in the steel section is not required.



#### Flush Fit

*Visible protrusion:* Zero  
The innovative Flush Fit Hollo-Bolt is entirely concealed within a drilled countersunk hole once installed, leaving no protrusion above the surface of the steel section - the perfect solution for architects!

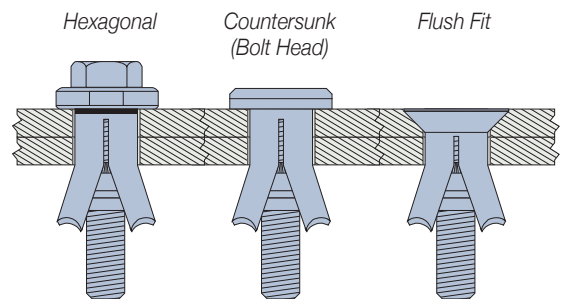

#### Also available: Engineered Solutions

*Visible protrusion:* Customised  
For the rare connection requirement that an off-the-shelf Hollo-Bolt cannot fulfil, Lindapter's Research & Development Facility has the capability to design and manufacture custom connection solutions. The example to the left shows a Security / Button Head. Please contact Lindapter to discuss your requirement.

### Availability of Head Variations

	High Clamping Force (HCF)					JS500	Stainless Steel	Sheraplex	Hot Dip Galv.
	M8	M10	M12	M16	M20				
Hex Head	✓	✓	✓	✓	✓	✓	✓	✓	✓
Countersunk	✓	✓	✓	✓	✓	✓	✓	✓	
Flush Fit	✓	✓	✓			✓	✓	✓	

➤ Sizes M16 and M20, known as the Hollo-Bolt (HCF), feature a patented **High Clamping Force** mechanism to produce three times more clamping force than the same sized product without the mechanism. The significance of clamping force and the superior performance of Lindapter's unique Hollo-Bolt (HCF) is illustrated on page 40.

**Hollo-Bolt & Hollo-Bolt (HCF)**

The Hollo-Bolt is available in two versions: the original 3-part design for general hollow section connections and the larger sized 5-part High Clamping Force (HCF) version, for higher strength structural connections.



**3-Part Hollo-Bolt**

**M8 M10 M12**

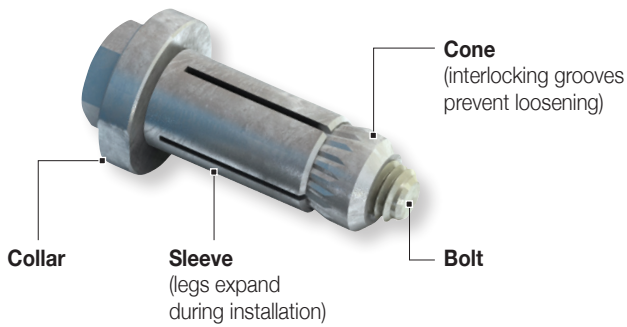

→ ← = Clamping Force

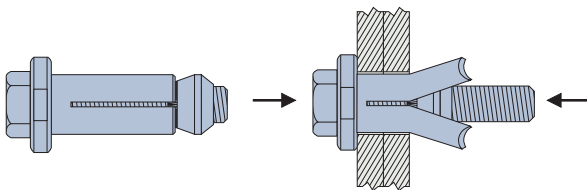

A typical connection is made by inserting the Hollo-Bolt into the pre-drilled holes of the fixture and hollow section. As the bolt head is tightened, the cone is pulled up the bolt thread, causing the legs of the sleeve to expand until the cone locks the sleeve against the inner wall of the hollow section.

At full tightening torque, a clamping action is set up between the fixture and steel section to form a secure connection. Once installed, only the head and collar are visible.

**5-Part Hollo-Bolt (HCF)**



**M16 M20**

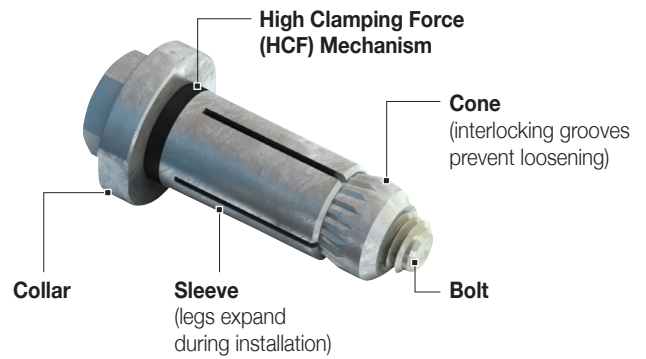

→ ← = Clamping Force

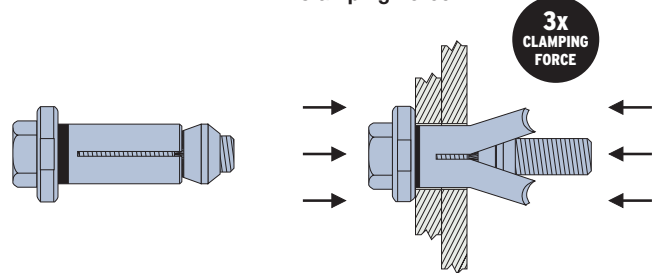

Working closely with Structural Engineers & Steel Fabricators, Lindapter identified the need for the larger M16 & M20 Hollo-Bolts to have an increased clamping force suitable for higher strength structural connections. Research & Development led to the invention of the patented 5-part design, optimised for superior performance.

The High Clamping Force (HCF) mechanism consists of a special washer that 'compresses' to significantly increase clamping force between the fixture and hollow section, when compared to a 3-part product of the same size, thereby reducing displacement.

**Hollo-Bolt (HCF) - Typical Performance Increase**

<p><b>5-Part Design - With HCF Mechanism</b> &gt; Hot Dip Galvanised, Size 2</p>		<p><b>3-Part Design - Without HCF Mechanism</b> &gt; Hot Dip Galvanised, Size 2</p>
--	---	---

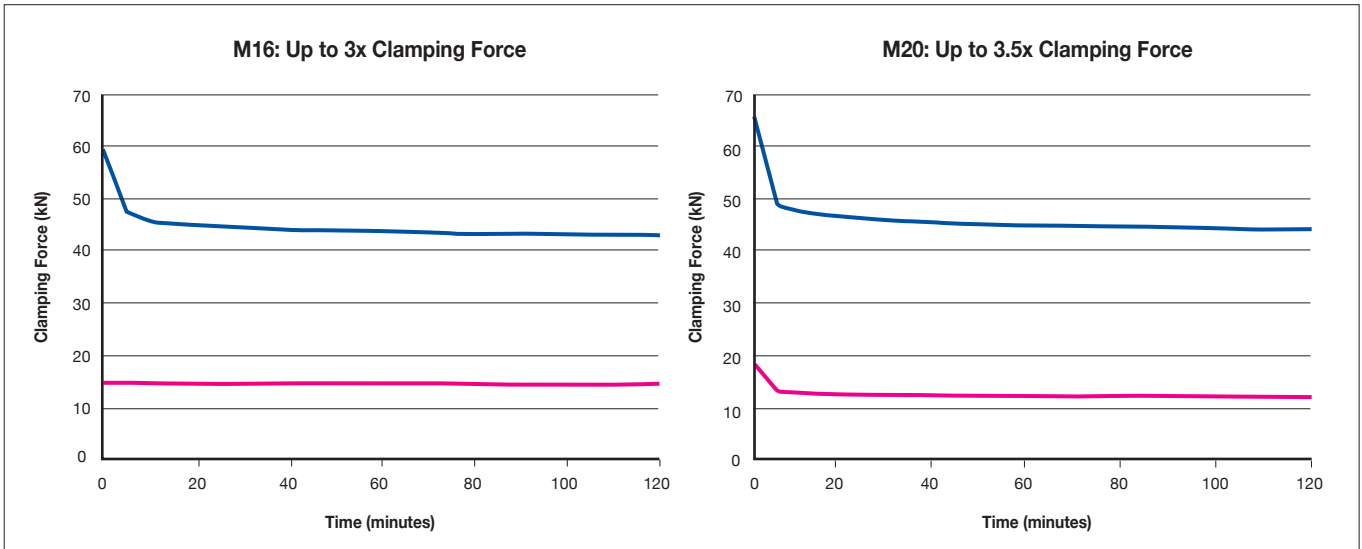

**Clamping Force**

As with any structural bolt, immediately after installation the bolt relaxes until a typical clamping force is reached. The typical clamping force of the Hollo-Bolt (HCF) is over three times higher than the same sized product without the HCF mechanism. This results in a more secure connection and a greater force that has to be overcome before displacement begins.

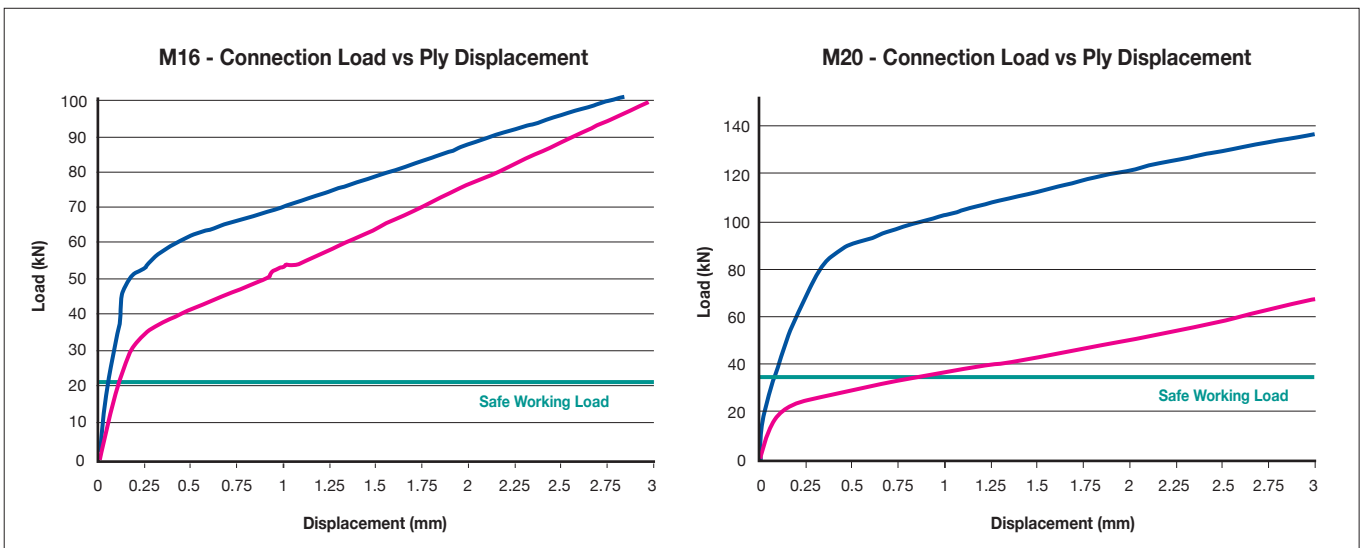

**Displacement**

The significance of increased clamping force is shown in the graphs above. The blue curve demonstrates the superior performance of the Hollo-Bolt (HCF) in contrast to M16 & M20 sized products without Lindapter's patented HCF mechanism (i.e. the 3-part design). At Safe Working Load, displacement (movement in the connection) is minimised when using the Hollo-Bolt (HCF) for a safer and more secure connection.

### Hollo-Bolt - Safe Working Loads

**a) Hexagonal**

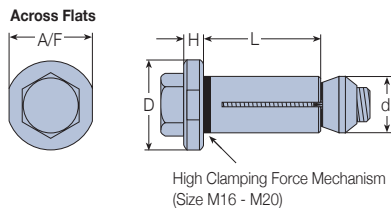

**b) Countersunk (Bolt Head)**

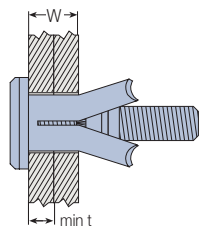

**c) Flush Fit**

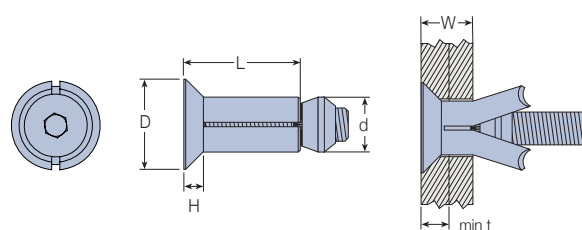

a) HEXAGONAL		b) COUNTERSUNK		Clamping Thickness W mm	Outer Ply <sup>1)</sup> min t mm	Sleeve		Height H mm	Collar		Tightening Torque Nm	Safe Working Loads <sup>2)</sup> (5:1 Factor of Safety)	
Product Code	Bolt Length mm	Product Code	Bolt Length mm			L mm	Outer Ø d mm		D mm	A/F mm		Tensile kN	Single Shear kN
HB08-1	M8 x 50	HBCSK08-1	M8 x 50	3 - 22	-	30							
HB08-2	M8 x 70	HBCSK08-2	M8 x 70	22 - 41	-	49	13.75	5	22	19	23	4.0	5.0
HB08-3	M8 x 90	HBCSK08-3	M8 x 90	41 - 60	-	68							
HB10-1	M10 x 55	HBCSK10-1	M10 x 50	3 - 22	-	30							
HB10-2	M10 x 70	HBCSK10-2	M10 x 70	22 - 41	-	48	17.75	6	29	24	45	8.5	10.0
HB10-3	M10 x 90	HBCSK10-3	M10 x 90	41 - 60	-	67							
HB12-1	M12 x 60	HBCSK12-1	M12 x 55	3 - 25	-	35							
HB12-2	M12 x 80	HBCSK12-2	M12 x 80	25 - 47	-	57	19.75	7	32	30	80	10.5	15.0
HB12-3	M12 x 100	HBCSK12-3	M12 x 100	47 - 69	-	79							
HB16-1	M16 x 75	HBCSK16-1	M16 x 70	12 - 29	8	41.5							
HB16-2	M16 x 100	HBCSK16-2	M16 x 100	29 - 50	8	63	25.75	8	38	36	190	21.0	30.0
HB16-3	M16 x 120	HBCSK16-3	M16 x 120	50 - 71	8	84							
HB20-1	M20 x 90	-	-	12 - 34	8	50							
HB20-2	M20 x 120	-	-	34 - 60	8	76	32.75	10	51	46	300	35.0	40.0
HB20-3	M20 x 150	-	-	60 - 86	8	102							

High Clamping Force (HCF)

➤ Sizes M16 and M20, known as the Hollo-Bolt (HCF), feature a patented **High Clamping Force** mechanism to produce three times more clamping force than the same sized product without the mechanism. The significance of clamping force and the superior performance of Lindapter's unique Hollo-Bolt (HCF) is illustrated on page 40.

**c) FLUSH FIT**

Product Code	Countersunk Bolt mm	Clamping Thickness W mm	Outer Ply min t mm	Sleeve		Collar		Installation Nut A/F mm	Tightening Torque Nm	Safe Working Loads <sup>2)</sup> (5:1 Factor of Safety)	
				Length L mm	Outer Ø d mm	Height H mm	Ø D mm			Tensile kN	Single Shear kN
HBFF08-1	M8 x 50	10 - 27	8	35				19	23	4.0	5.0
HBFF08-2	M8 x 70	27 - 45	8	54	13.75	5	24	19	23	4.0	5.0
HBFF08-3	M8 x 90	45 - 64	8	73							
HBFF10-1	M10 x 50	12 - 27	10	36				24	45	8.5	10.0
HBFF10-2	M10 x 70	27 - 45	10	54	17.75	6	30	24	45	8.5	10.0
HBFF10-3	M10 x 90	45 - 64	10	73							
HBFF12-1	M12 x 55	12 - 30	10	42				30	80	10.5	15.0
HBFF12-2	M12 x 80	30 - 52	10	64	19.75	7	33	30	80	10.5	15.0
HBFF12-3	M12 x 100	52 - 74	10	86							

1) Sizes M16 and M20 require the thickness of the outer ply (min t) to be at least 8mm. If necessary, spacer washers should be used beneath the collar to increase the thickness to 8mm.

2) The Hollo-Bolt can be used on a wide variety of steel hollow shape sections; safe working loads shown are based on use in S275 structural hollow section. The safe working loads, in both tension and shear, are applicable to the Hollo-Bolt only. Failure of the section, particularly on those with thin walls and a wide chord face, could occur at a lower figure and its strength should be checked by a qualified structural engineer.

The tables above state the safe working loads with a 5:1 Factor of Safety and should be used for secondary applications. For primary design, please consult the guide **Joints in Steel Construction - Simple Connections**.

The guide provides design guidance for the use of Hollo-Bolt and gives essential information for structural steelwork connections for use in buildings designed by the 'Simple Method' i.e. braced frames where connections carry mainly shear and axial loads only. To obtain further details on the Simple Connections guide please contact:

**The Steel Construction Institute** T: +44 (0) 1344 636 525 / F: +44 (0) 1344 636 570 / [www.steel-sci.com](http://www.steel-sci.com)



Published by SCI/BCSA Connections Group. Publication Number: P212 / ISBN 1 85942 072 9. Lindapter is a member of SCI and BCSA

### Hollo-Bolt Characteristic Values of Tensile and Shear Resistance

taken from ETA-10/0416 (www.lindapter.com/about/CE)



#### Hollo-Bolt Hexagonal

Product Code	Nominal Size	Tensile $F_{t,Rk}$ kN	Shear $F_{v,Rk}$ kN	Material Strength of Sleeve $N/mm^2$
HB08	M8	23.1	32.9	430
HB10	M10	39.6	54.2	430
HB12	M12	45.8	71.0	430
<b>HCF</b> HB16	M16	84.3	139.0	430
<b>HCF</b> HB20	M20	124.0	211.0	390

#### Hollo-Bolt Hexagonal Stainless Steel

Product Code	Nominal Size	Tensile $F_{t,Rk}$ kN	Shear $F_{v,Rk}$ kN	Material Strength of Sleeve $N/mm^2$
HBST08	M8	26.8	30.7	500
HBST10	M10	46.0	51.0	500
HBST12	M12	53.3	65.0	500
<b>HCF</b> HBST16	M16	98.0	128.0	500
<b>HCF</b> HBST20	M20	154.0	205.0	500

#### Hollo-Bolt Countersunk (Bolt Head)

Product Code	Nominal Size	Tensile $F_{t,Rk}$ kN	Shear $F_{v,Rk}$ kN	Material Strength of Sleeve $N/mm^2$
HBCSK08	M8	23.1	32.9	430
HBCSK10	M10	39.6	54.2	430
HBCSK12	M12	45.8	71.0	430
<b>HCF</b> HBCSK16	M16	84.3	139.0	430

#### Hollo-Bolt Countersunk (Bolt Head) Stainless Steel

Product Code	Nominal Size	Tensile $F_{t,Rk}$ kN	Shear $F_{v,Rk}$ kN	Material Strength of Sleeve $N/mm^2$
HBSTCSK08	M8	26.8	30.7	500
HBSTCSK10	M10	46.0	51.0	500
HBSTCSK12	M12	53.3	65.0	500
<b>HCF</b> HBSTCSK16	M16	98.0	128.0	500

➤ Sizes M16 and M20, known as the Hollo-Bolt (HCF), feature a patented **High Clamping Force** mechanism to produce three times more clamping force than the same sized product without the mechanism. The significance of clamping force and the superior performance of Lindapter's unique Hollo-Bolt (HCF) is illustrated on page 40.

#### Hollo-Bolt Flush Fit

Product Code	Nominal Size	Tensile $F_{t,Rk}$ kN	Shear $F_{v,Rk}$ kN	Material Strength of Sleeve $N/mm^2$
HBFF08	M8	23.1	32.9	430
HBFF10	M10	39.6	54.2	430
HBFF12	M12	45.8	71.0	430

#### Hollo-Bolt Flush Fit Stainless Steel

Product Code	Nominal Size	Tensile $F_{t,Rk}$ kN	Shear $F_{v,Rk}$ kN	Material Strength of Sleeve $N/mm^2$
HBSTFF08	M8	26.8	30.7	500
HBSTFF10	M10	46.0	51.0	500
HBSTFF12	M12	53.3	65.0	500

#### Hollo-Bolt Button Head / Security

\* Please contact Lindapter to discuss the available options.

Product Code	Nominal Size	Tensile $F_{t,Rk}$ kN	Shear $F_{v,Rk}$ kN	Material Strength of Sleeve $N/mm^2$
HBBH/HBFT/HBPR	M8	23.1	32.9	430
HBBH/HBFT/HBPR	M10	39.6	54.2	430
HBBH/HBFT/HBPR	M12	45.8	71.0	430

➤ **The Characteristic Values for the Hollo-Bolt listed in the above tables are for use when designing bolted connections to Eurocode 3 only, these are not standard safe working loads.**

Hollo-Bolt lengths 1, 2 and 3 are covered by this ETA 10/0416. The characteristic values are used to determine the design resistance of the Hollo-Bolt. The design resistance is calculated by dividing the characteristic value by a partial factor  $\gamma_{m2}$ . The partial factor is a nationally determined parameter (for example:  $\gamma_{m2} = 1.25$  in the UK).

For Hollo-Bolt safe working loads with a factor of safety of 5:1 please refer to the Hollo-Bolt tables on page 42 of this catalogue. The characteristic values are valid for the Hollo-Bolt assembly itself, in any connection detail the design resistance of the connection may be limited to a lesser value. For example, when the thickness of the connected component is small, pull out failure may occur before failure of the Hollo-Bolt.

Design checks should be carried out on the section member to determine the static design resistance.

The SCI Greenbook publication P.358 Joints in Steel construction, Simple Joints to Eurocode 3 contains a number of checks on the section. The characteristic values are only valid when the Hollo-Bolts are installed as per our installation instructions. To obtain further details on the Simple Connections guide please contact:

**The Steel Construction Institute** T: +44 (0) 1344 636 525 / F: +44 (0) 1344 636 570 / www.steel-sci.com



Published by SCI/BCSA Connections Group. Publication Number: P358 / ISBN 978-1-85942-201-4. Lindapter is a member of SCI and BCSA



**Hexagonal & Countersunk Head**



**Drilling & Preparation**

Ensure that holes are drilled in both the fixture and the section according to the drilling guidance below. Please note that clearance holes are slightly larger than standard bolt clearance holes to accommodate the sleeve and cone.

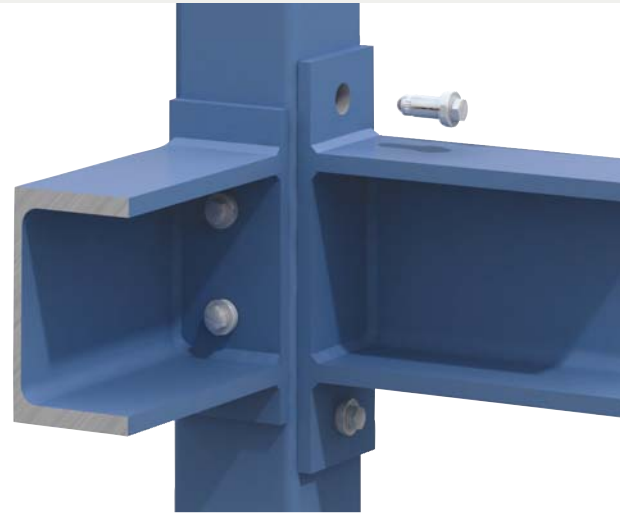

Hexagonal	Type	Clearance Hole Ø	Hole Distances		Edge Distances
	Countersunk		min A mm	min B mm	B+C mm
HB08	HBCSK08	14 (+1.0 / -0.2)	35	13	> 17.5
HB10	HBCSK10	18 (+1.0 / -0.2)	40	15	> 22.5
HB12	HBCSK12	20 (+1.0 / -0.2)	50	18	> 25.0
HB16	HBCSK16	26 (+2.0 / -0.2)	55	20	> 32.5
HB20	-	33 (+2.0 / -0.2)	70	25	> 33.0

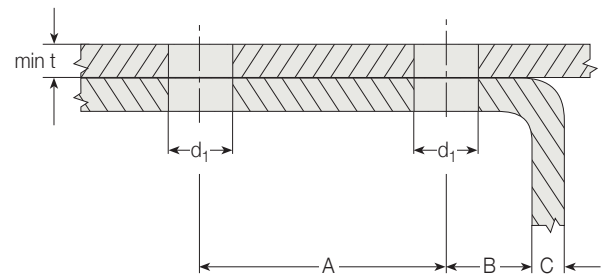

➤ Sizes M16 and M20 require the thickness of the outer ply (min t) to be at least 8mm. If necessary, spacer washers should be used beneath the collar to increase the thickness to 8mm.

**Installation**

1. Align pre-drilled fixture and section and insert Holo-Bolt<sup>a)</sup>.

2. Grip the Holo-Bolt collar with an open ended spanner.

3. Using a calibrated torque wrench, tighten the central bolt to the recommended torque<sup>b)</sup>.

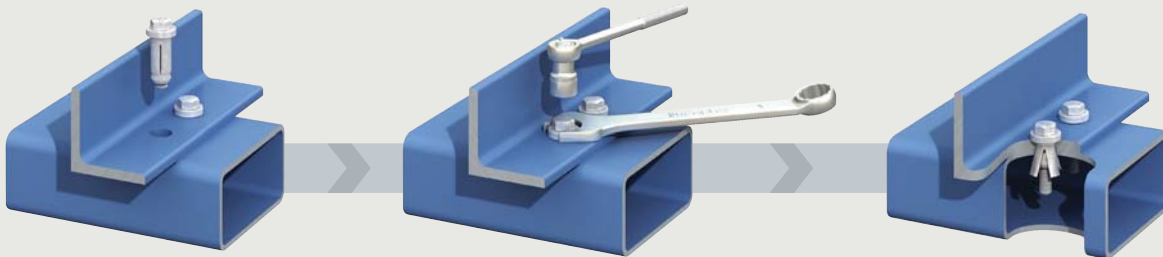

- a) Before tightening, ensure that the materials that are to be connected together are touching. See Page 42 for tightening torque.
- b) Power tools, such as an impact wrench, may be used to speed up the tightening of the Holo-Bolt. However, when using power tools, always complete the tightening process with a torque wrench to ensure the correct torque is applied to the Holo-Bolt.

**Flush Fit**



**Drilling & Preparation**

Ensure that countersunk holes are drilled in the fixture, and standard holes are drilled in the section, according to the drilling guidance below. Please note that clearance holes are slightly larger than standard bolt clearance holes to accommodate the sleeve and cone.

Type	Clearance Hole Ø $d_1$ mm	Countersunk Ø Depth		Hole Distances		Edge Distances B+C mm
		$d_2$ mm	$t_1$ mm	min A mm	min B mm	
HBFF08	14 (+1.0 / -0.2)	27	6.5	35	13	> 17.5
HBFF10	18 (+1.0 / -0.2)	31	6.5	40	15	> 22.5
HBFF12	20 (+1.0 / -0.2)	35	7.5	50	18	> 25.0

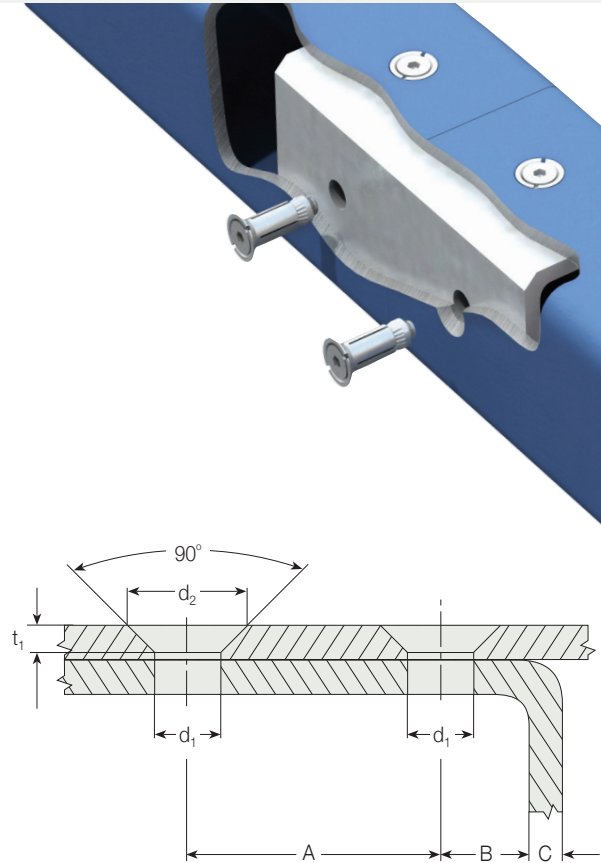

**Installation**

1. Align pre-drilled fixture and section and insert Holo-Bolt<sup>a)</sup>.
2. Apply installation nut and grip with an open ended adjustable spanner.
3. Using a calibrated torque wrench, tighten the central countersunk bolt to the recommended torque<sup>b)</sup>.

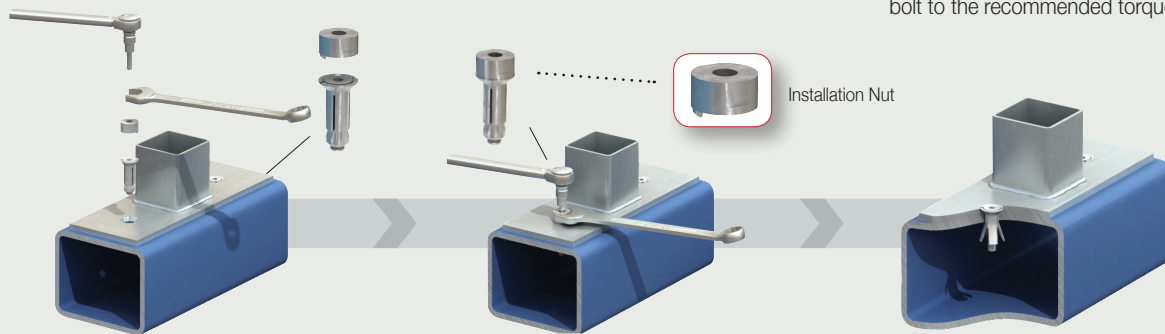

- a)** Before tightening, ensure that the materials that are to be connected together are touching. See Page 42 for tightening torque.
- b)** Power tools, such as an impact wrench, may be used to speed up the tightening of the Holo-Bolt. However, when using power tools, always complete the tightening process with a torque wrench to ensure the correct torque is applied to the Holo-Bolt.



Hollo-Bolt Hexagonal

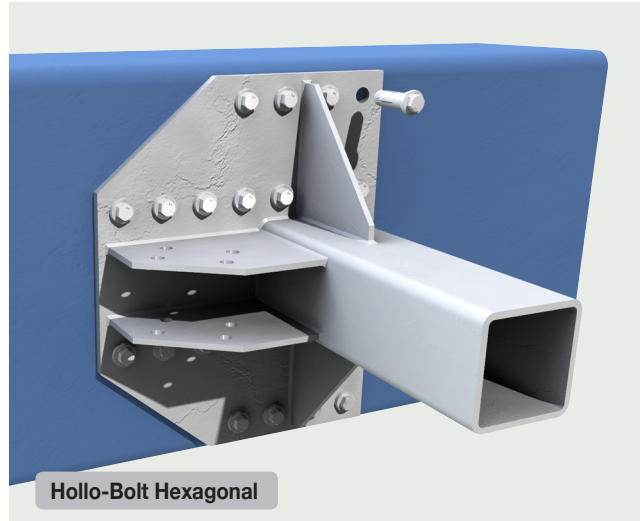

Hollo-Bolt Hexagonal

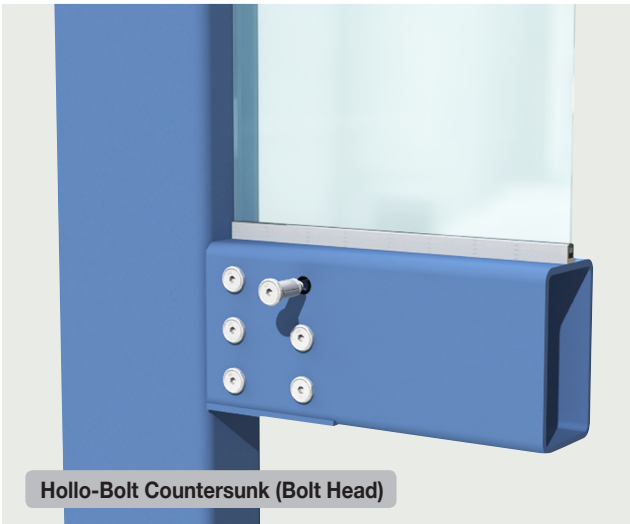

Hollo-Bolt Countersunk (Bolt Head)

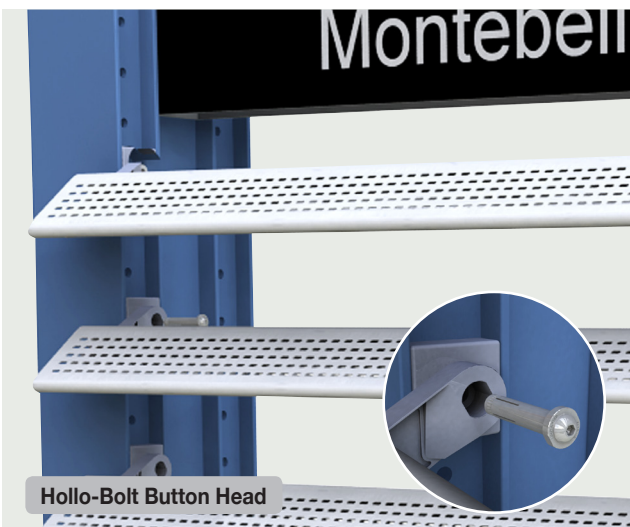
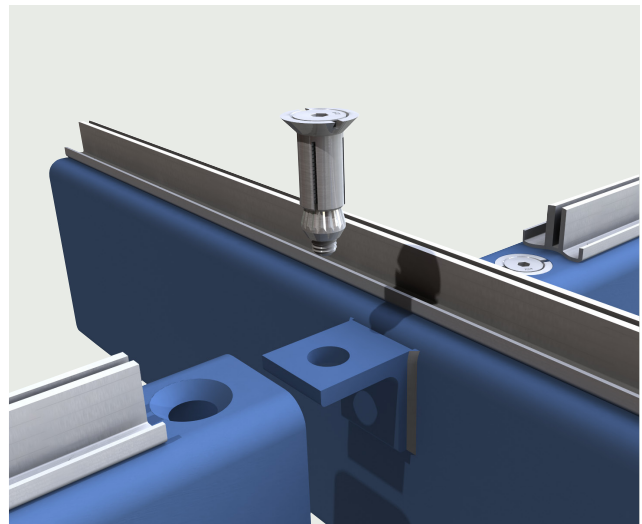

Hollo-Bolt Button Head

For more information on the Hollo-Bolt, including a Global Project Portfolio and FAQs, request the new Hollo-Bolt brochure today.

To request a copy, email [enquiries@lindapter.com](mailto:enquiries@lindapter.com) or visit the Hollo-Bolt website for a free download.



Visit the website:  
[www.hollo-bolt.com](http://www.hollo-bolt.com)

